

800 Series

TELESCOPIC BOOM LIFTS



**Narrow Fixed
Width - Low GVW**



**Jobsite Proven
Performance**



**750 lbs. Capacity
with JIB**



**800S
860SJ**

www.jlg.com



Optimum Productivity – Lower Owning and Operating Costs

The new Models 800S and 860SJ telescoping boom lifts from JLG feature an innovative boom design that allows for a narrow fixed working width and low gross vehicle weight. The results are machines with unsurpassed performance and maneuverability designed to optimize your productivity and reduce your owning and operating costs.

Optimum Performance

Time wasted is money lost! The 800 Series gets you from the ground to 80 ft. (24.38 m) in less than 67 seconds – 40% faster than the competition. The 800 Series lets you spend more time working and less time getting there.



Service and Reliability

Preventative maintenance and downtime are facts of life for any piece of equipment. The 800 Series is designed to reduce these costs and optimize machine uptime. Better fuel efficiency, a swing-out engine tray and JLG's Control ADE™ System are just some of the features that help keep your owning and operating costs low and your machine working.

Fixed Width Plus Low GWW

Both the Models 800S and 860SJ are housed on an 8'2" (2.49 m) fixed-width frame. Extendable axles are not needed which means faster set-up times on the job and less components requiring maintenance. Plus, the narrow working width allows access to those congested areas off-limits to wider machines.

Oscillating Axle

Construction jobsite conditions range from deep mud to sand to deeply rutted, hard-packed dirt. Sometimes on the same job! The standard oscillating axle provides a smoother ride and better traction in all types of conditions. 45% gradeability on 4x4 models reflects real jobsite performance.

Operator Preferred Controls – Now with the Control ADE™ System

JLG's Exclusive Advanced Design Electronics (Control ADE™) System helps optimize productivity while lowering your owning and operating costs.

- **Higher Productivity** – The Control ADE System by JLG provides smoother machine functions, increased fuel efficiency and reduced emissions.
- **Commonality of Components** – The Control ADE System is standard across all JLG engine powered boom models.
- **Enhanced Reliability** – The Control ADE System significantly reduces the number of wires and connections.
- **Improved Serviceability** – The Control ADE System self-test capability reduces troubleshooting time and identifies potential problems.
- **Enhanced Performance** – The Control ADE System allows function speeds and options to be customized to meet customer preferences.





High Capacity

Another industry first – dual capacity ratings on a jib machine! Industry-best capacities through the majority of the work envelope increase your productivity by allowing more workers and materials in the platform. This is especially critical for applications requiring extra capacity such as steel erection, mechanical contracting and glazing.



Options to Create Your Workstation in the Sky™

Transform your Model 800S or 860SJ into a true Workstation in the Sky™ Product with exclusive options and accessories from JLG. Whether designed for a specific application like the SkyWelder™ Package or to meet a variety of needs like the SkyPower™ Package, JLG has many options available to increase your productivity and enhance your work environment.



SkyPower™ Package

JLG delivers more power where you need it with the SkyPower™ Package. Machines outfitted with the SkyPower Package include a 7500W self-contained generator, plus a power cable and a 1/2 inch air line routed through the boom's power track to the platform. As an added benefit, the SkyPower Package is designed to work with various add-on accessories, including the SkyWelder™ Package.

SkyWelder™ Package

Looking for a better way to meet your overhead welding needs? Equip your new 800 Series boom lifts with JLG's innovative SkyWelder™ Package. A 250-amp welder that includes a 7500W generator provides the power you need to effectively and efficiently complete the job. No more unsightly and dangerous welding leads hanging from platforms. No more extra costs for stand-alone welders and power supplies.



Nite-Bright™ Package

See your work environment in a whole new light with the Nite-Bright™ Package. JLG's all new Nite-Bright Package consists of six 40-watt lights—four chassis mounted lights and two platform mounted lights. The Nite-Bright Package illuminates your work site plus the area around the chassis for increased visibility, and is perfect for tunnel or mine applications, nighttime work or any job with low lighting levels.

Pipe Rack Accessory

JLG's exclusive Pipe Rack Accessory is designed to secure pipes close to where they are needed. The pipe rack is mounted to the top platform rail and can hold up to 180 lbs. (80 kg) of pipe.



Keep checking www.jlg.com for additional Tools of the Trade.

JLG MODEL 800S/860SJ SERIES

PERFORMANCE FEATURES

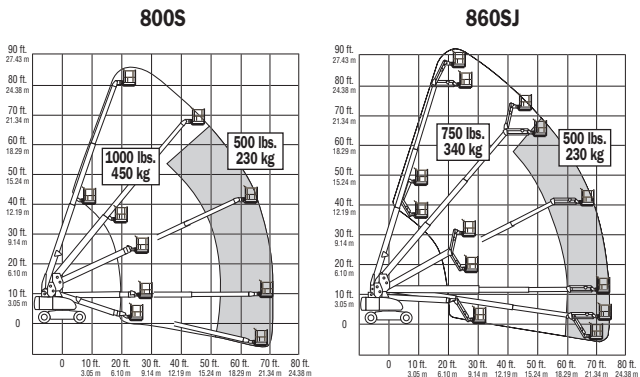

REACH SPECIFICATIONS

| | |
|--|--|
| Platform Height (800S) | 80 ft. (24.38 m) |
| Platform Height (860SJ) | 86 ft. (26.21 m) |
| Horizontal Reach (800S) | 71 ft. (21.64 m) |
| Horizontal Reach (860SJ) | 75 ft. (22.86 m) |
| Swing | 360 Degrees Continuous |
| Platform Capacity - Restricted (800S) | 1,000 lbs. (450 kg) |
| Platform Capacity - Restricted (860SJ) | 750 lbs. (340 kg) |
| Platform Capacity - Unrestricted | 500 lbs. (230 kg) |
| Platform Rotator | 180 Degrees |
| Jib - 860SJ Only - (Range of Articulation) | 6 ft. (1.83 m) 130 Degrees (+70, -60) |

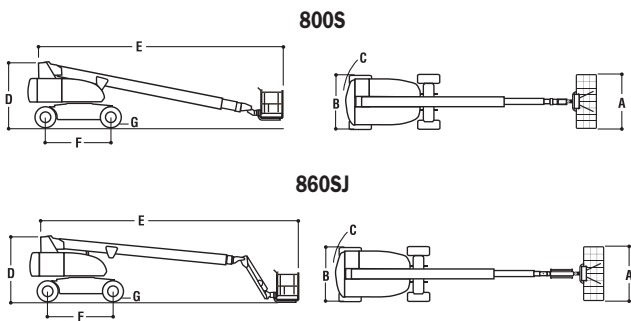

DIMENSIONAL DATA

| | |
|-------------------------------------|------------------------------------|
| A. Platform Size | 36 x 96 in. (0.91 x 2.44 m) |
| B. Overall Width | 8 ft. 2 in. (2.49 m) |
| C. Tailswing | 4 ft. 8 in. (1.42 m) |
| D. Stowed Height (800S) | 9 ft. 11 in. (3.02 m) |
| D. Stowed Height (860SJ) | 10 ft. (3.05 m) |
| E. Stowed Length (800S) | 37 ft. 3 in. (11.35 m) |
| E. Stowed Length (860SJ) | 40 ft. (12.19 m) |
| F. Wheel Base | 10 ft. (3.05 m) |
| G. Ground Clearance | 12 in. (30 cm) |
| Gross Vehicle Weight (800S) | 32,675 lbs. (14,821 kg) |
| Gross Vehicle Weight (860SJ) | 36,350 lbs. (16,488 kg) |
| Max Ground Bearing Pressure (800S) | 71.5 psi (5.0 kg/cm ²) |
| Max Ground Bearing Pressure (860SJ) | 92.4 psi (6.5 kg/cm ²) |

CHASSIS

| | |
|--------------------------|-----------------------|
| Drive Speed - 2WD/4WD | 3.5 mph (5.6 kph) |
| Gradeability - 2WD/4WD | 30%/45% |
| Turning Radius - Inside | 12 ft. (3.66 m) |
| Turning Radius - Outside | 22 ft. 6 in. (6.86 m) |
| Tires/Type | Pneumatic 15 x 24.5 |

POWER SOURCE

| | |
|------------------------------------|-------------------|
| Dual Fuel Engine, Ford LRG-425 EFI | 82 hp (61 kW) |
| Diesel Engine, Deutz F4M2011 | 65 hp (48 kW) |
| Fuel Tank Capacity | 31 gal. (117.3 L) |
| Hydraulic Reservoir | 40 gal. (151.4 L) |
| Auxiliary Power | 12V DC |

Standard Features

- 36 in. x 96 in. (0.91 x 2.44 m) Platform
- Dual Rated Capacities
- Oscillating Axle
- Inward Swinging Gate
- 180 Degree Hydraulic Platform Rotator
- 110V-AC Receptacle in the Platform
- 5 Degree Tilt Alarm/Indicator Light
- Swing-Out Engine Tray
- 12V-DC Auxiliary Power
- Hourmeter
- Control ADE™ System
- Proportional Controls
- Gull-Wing Engine Hood
- Hydrostatic Drive
- Operator Tool Tray
- Platform Console Machine Status Light Panel*
- Lifting/Tie Down Lugs
- Engine Distress Warning
- 15 x 24.5 Rim Protector Lug Tread Tires
- Engine Distress Shutdown-selectable via analyzer
- Fuel Gauge

*Provides indicator lights at platform control console for system distress, 5 degree tilt light, and foot switch status.

Options

- 36 in. x 72 in. (0.91 x 1.83 m) Platform
- Light Package¹
- Alarm Package²
- 1/2 in. Air Line to Platform
- Soft Touch System
- 15 x 24.5 Foam Filled Tires
- 18 x 24.5 Foam Filled Tires
- 18 x 24.5 Foam Filled Sand/Turf Tires
- 2500W Generator
- Tow Package
- Cold Weather Start Kit (Ford)³
- Cold Weather Start Kit (Deutz)³
- Hostile Environment Kit⁴

1. Includes head and tail lights, and platform work lights.
2. Includes all motion alarm and flashing amber beacon.
3. Includes engine block heater (Ford) or glow plugs (Deutz), battery heater and oil tank heater.
4. Includes console cover, boom wipers and cylinder bellows.

Accessories

- SkyPower™ Package**—Includes 7500W generator, power cable to platform, and 1/2 in. air line to platform.
- SkyWelder™ Package**— Includes SkyPower Package, 250-amp welder in the platform, leads, clamp and stinger.
- Nite-Bright™ Package**—Includes six 40-watt lights (platform and chassis mounted).
- Pipe Rack**—Platform mounted-180 lbs. (80 kg) capacity.

The JLG "1 & 5" Warranty for Models 800S & 860SJ

JLG Industries, Inc. backs our products with our exclusive "1 & 5" Warranty. We provide coverage on all products for one (1) full year, and cover all specified major structural components for five (5) full years. Due to continuous product improvements, we reserve the right to make specification and/or equipment changes without prior notification. This machine meets or exceeds applicable OSHA Regulations in 29 CFR 1910.67, 29 CFR 1926.453, ANSI A92.5-1992 and CSA standard CAN3-B354.4-M82 as originally manufactured for intended applications.

JLG Industries, Inc.

1 JLG Drive, McConnellsburg, PA 17233-9533
 Telephone 717-485-5161 Toll-free in US 877-JLG-LIFT
 Fax 717-485-6417
 www.jlg.com

Printed in USA
 FORM NO.: SS-800S-1101-7M
 PART NO.: 3131024

